

TECHNICAL GUIDE

SINGLE PIECE AIR HANDLERS

FOR USE WITH SPLIT-SYSTEM COOLING & HEAT PUMPS

HEAT PUMP MODELS:

F*FP

VARIABLE SPEED MODEL:

F*FV



Due to continuous product improvement, specifications are subject to change without notice.

Visit us on the web at www.york.com

Additional rating information can be found at www.ahridirectory.org.

DESCRIPTION

This fan coil unit provides the flexibility for installation in any upflow or horizontal application. These versatile models may be used for split-system cooling or heat pump operation. Compact cabinets along with return air options in both the upflow and horizontal positions allow this unit to fit into tight spaces such as attics, crawl spaces, and closets.

NOTE: For matching condensing units and performance data, refer to condenser technical guides.

FEATURES

CABINET - The compact and sturdy cabinet is protected with a durable, attractive finish to prevent rust. The cabinet is also insulated to prevent cabinet sweating. F*FP and F*FV models have 3/4 inch insulation.

BLOWERS - Blowers are sized to circulate air both quietly and efficiently. The direct-drive, multi-speed motors provide a selection of air volume to match any application. Motor speeds may be selected via quick connect terminal at the motor. Slide-out blower/motor assemblies provide for easy servicing.

COILS - Using the latest in heat transfer technology, the rifled tube coil/aluminum fin coils produce high performance ratings and provide long lasting quality. The coils are capable of bottom return air in the upflow position, and right or left end return air in the horizontal position.

FACTORY INSTALLED TXV - Air handler models F*FP and F*FV have factory installed R-22 TXV metering device which can be easily converted to R-410A by changing the bolt-on TXV

FLEX-COILS - Available without a factory installed metering device. For added application flexibility an orifice metering device or R-22 or R-410A TXV should be installed on “**Flex-coils**” in the field to meet the required refrigerant choice.

ELECTRIC HEATERS - Models providing up to 25kw of heat are available as field installed accessories. Electric heaters are available in both single and three phase.

EASY INSTALLATION - These fan coil units are designed to provide the lowest total installation cost. Accessible color coded control wiring, top and side power wiring knockouts, easy to install drain connections and electric heaters all combine to minimize installed cost on every job.

CONTROL BOARD - The control board is equipped with low voltage terminal strips for easy installation. The control board is also equipped with plug-in receptacles for the auxiliary heaters.

DIMENSIONS

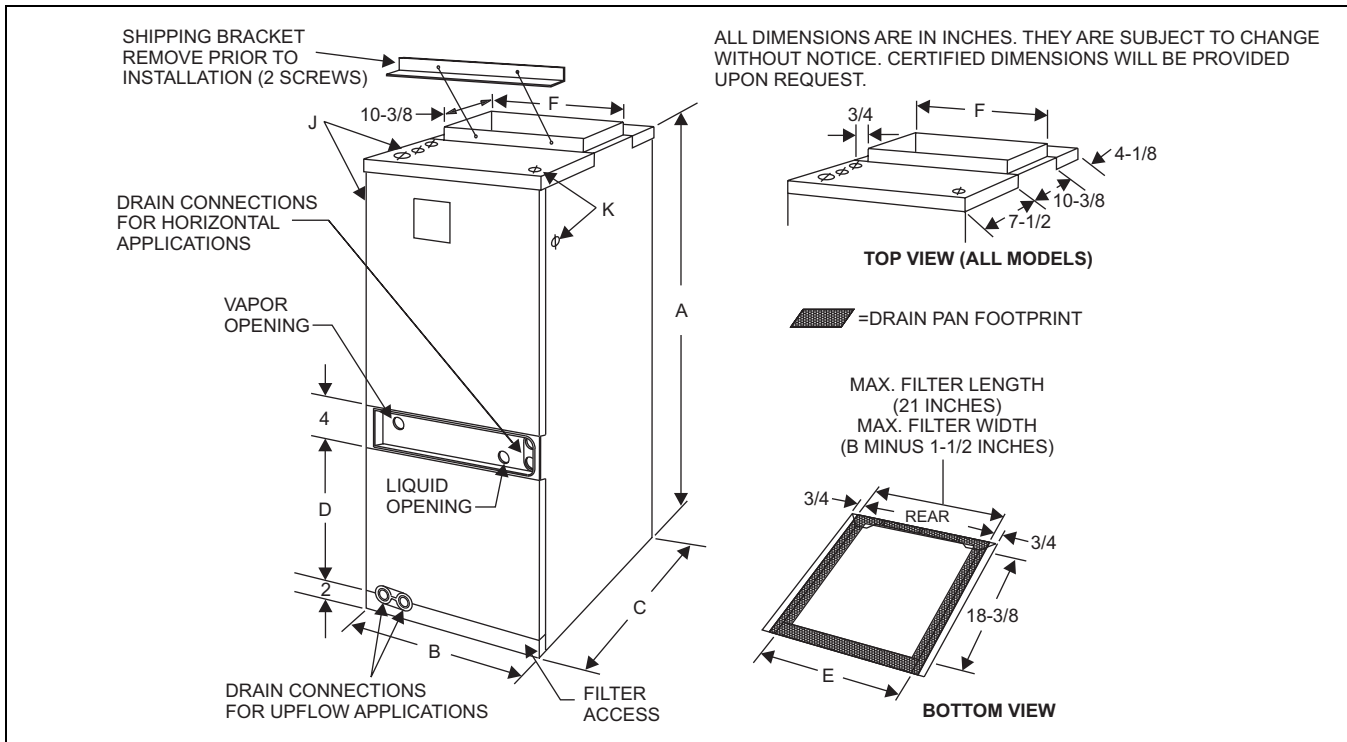

Model ¹	Dimensions						Wiring K.O.s ²		Refrigerant Connections Line Size	
	A	B	C	D	E	F	J	K	Liquid	Vapor
	Height	Width	Depth				Power	Control		
F4FP024H06T**	40-3/4	18	22	12-1/8	14-7/8	16-1/2	7/8 (1/2) 1-3/8 (1)	7/8 (1/2)	3/8	5/8
F4FP030H06T**	40-3/4	18			14-7/8	16-1/2				3/4
F4FP036H06T**	40-3/4	21-1/2			18-3/8	20				3/4
F4FP040H06T**	40-3/4	21-1/2			18-3/8	20				7/8
F4FP042H06T**	40-3/4	21-1/2			18-3/8	20				7/8
F4FP045H06T**	50-3/4	24	17-3/8	20-7/8	22-1/2	7/8 (1/2) 1-3/8(1) 1-23/32 (1-1/4)	7/8 (1/2)	3/8	7/8	
F5FP048H06T**	50-3/4	24			20-7/8				22-1/2	7/8
F5FP060H06T**	50-3/4	24			20-7/8				22-1/2	7/8
F4FV060H06T**	50-3/4	24			20-7/8				22-1/2	7/8

1. All models only available with factory installed horizontal drain pan.
 2. Actual conduit size is shown in parenthesis.

COIL TECHNICAL DATA

Models	Application	Refrigerant Connection Type	Face Area (Sq. Ft.)	Deep Rows	Fins Per Inch	Coil Slab Size		Tube Geometry	Tube Dia.	Fin. Type	Metering Device
						H	W				
F4FP024H06T2A	A/C & HP	Sweat	3.40	2	14	14	17.5	1 x .886	3/8	Enhanced	TXV-2A
F4FP024H06T2B	A/C & HP	Sweat	3.40	2	14	14	17.5	1 x .886	3/8	Enhanced	TXV-2B
F4FP024H06T3X	A/C & HP	Sweat	3.40	2	14	14	17.5	1 x .886	3/8	Enhanced	None
F4FP030H06T2A	A/C & HP	Sweat	3.89	2	14	16	17.5	1 x .886	3/8	Enhanced	TXV-2A
F4FP030H06T3X	A/C & HP	Sweat	3.89	2	14	16	17.5	1 x .886	3/8	Enhanced	None
F4FP036H06T2A	A/C & HP	Sweat	3.40	3	12	14	17.5	1 x .886	3/8	Enhanced	TXV-2A
F4FP036H06T3X	A/C & HP	Sweat	3.40	3	12	14	17.5	1 x .886	3/8	Enhanced	None
F4FP040H06T2A	A/C & HP	Sweat	3.89	3	11	16	17.5	1 x .886	3/8	Enhanced	TXV-2A
F4FP040H06T2C	A/C & HP	Sweat	3.89	3	11	16	17.5	1 x .886	3/8	Enhanced	TXV-2C
F4FP040H06T3X	A/C & HP	Sweat	3.89	3	11	16	17.5	1 x .886	3/8	Enhanced	None
F4FP042H06T2A	A/C & HP	Sweat	3.89	3	11	16	17.5	1 x .886	3/8	Enhanced	TXV-2A
F4FP042H06T2C	A/C & HP	Sweat	3.89	3	11	16	17.5	1 x .886	3/8	Enhanced	TXV-2C
F4FP042H06T3X	A/C & HP	Sweat	3.89	3	11	16	17.5	1 x .886	3/8	Enhanced	None
F4FP045H06T2C	A/C & HP	Sweat	5.83	3	12	24	17.5	1 x .886	3/8	Enhanced	TXV-2C
F4FP045H06T3X	A/C & HP	Sweat	5.83	3	12	24	17.5	1 x .886	3/8	Enhanced	None
F5FP048H06T2C	A/C & HP	Sweat	5.35	3	12	22	17.5	1 x .886	3/8	Enhanced	TXV-2C
F5FP048H06T3X	A/C & HP	Sweat	5.35	3	12	22	17.5	1 x .886	3/8	Enhanced	None
F5FP060H06T2C	A/C & HP	Sweat	5.83	3	12	24	17.5	1 x .886	3/8	Enhanced	TXV-2C
F5FP060H06T3X	A/C & HP	Sweat	5.83	3	12	24	17.5	1 x .886	3/8	Enhanced	None
F4FV060H06T2C	A/C & HP	Sweat	5.83	3	12	24	17.5	1 x .886	3/8	Enhanced	TXV-2C
F4FV060H06T3X	A/C & HP	Sweat	5.83	3	12	24	17.5	1 x .886	3/8	Enhanced	None

COOLING CAPACITY

Blower Model	Rated CFM	Entering Air °F (Dry / Wet Bulb)	MBH @ Evaporator Temperature and Corresponding Pressure °F / PSIG			
			35 / 61.5	40 / 68.5	45 / 76.0	50 / 84.0
Upflow / Horizontal Positions Only						
F4FP024H06T**	830	85 / 72	36.3	33.0	29.5	25.6
		80 / 67	33.4	30.2	26.7	23.1
		75 / 62	27.4	24.3	21.0	17.7
		70 / 57	22.2	19.3	16.2	12.6
F4FP030H06T**	1050	85 / 72	41.5	37.8	33.7	29.5
		80 / 67	36.2	32.4	28.6	24.5
		75 / 62	29.1	25.3	24.0	19.2
		70 / 57	24.1	21.5	18.7	15.8
F4FP036H06T**	1250	85 / 72	53.4	48.6	43.4	38.3
		80 / 67	42.8	37.8	33.1	28.2
		75 / 62	33.4	28.1	30.6	22.8
		70 / 57	28.7	26.5	24.5	22.8
F4FP040H06T**	1050	85 / 72	55.3	47.5	39.6	31.2
		80 / 67	44.2	37.1	30.2	23.1
		75 / 62	34.5	27.5	22.4	18.7
		70 / 57	29.6	26.0	22.4	18.7
F4FP042H06T**	1400	85 / 72	88.4	76.0	63.3	50.0
		80 / 67	70.8	59.4	48.4	37.0
		75 / 62	55.2	43.9	35.8	29.9
		70 / 57	47.4	41.5	35.8	29.9
F4FP045H06T**	1400	85 / 72	92.7	78.1	63.4	48.1
		80 / 67	74.2	61.3	48.4	35.4
		75 / 62	57.8	45.3	35.7	28.6
		70 / 57	49.7	42.8	35.7	28.6
F5FP048H06T**	1600	85 / 72	100.5	86.4	72.0	56.8
		80 / 67	80.4	67.5	55.0	42.1
		75 / 62	62.7	49.9	40.7	34.0
		70 / 57	53.9	47.2	40.7	34.0
F5FP060H06T**	1850	85 / 72	119.9	101.0	82.0	62.2
		80 / 67	96.0	79.2	62.6	45.8
		75 / 62	74.8	58.6	46.2	37.0
		70 / 57	64.3	55.4	46.2	37.0
F4FV060H06T**	1980	85 / 72	122.0	103.1	84.1	64.3
		80 / 67	98.1	81.3	64.7	47.9
		75 / 62	76.9	60.7	50.3	39.1
		70 / 57	66.4	57.5	48.3	39.1

ACCESSORIES

Refer to Price Manual for specific model numbers.

VERTICAL SUSPENSION KIT - The suspension kit is designed to be used with all sizes of fan coil units whenever the application requires vertical suspension of the unit.

ELECTRIC HEATERS - Models shown under Electrical Data include sequencers and temperature dual limit switches for safe, efficient operation. Circuit breakers are provided where shown.

BOLT-ON THERMAL EXPANSION VALVE - R-22 and R-410A TXV kits are available for enhanced efficiency. These fan coil units have either factory installed R-22 TXV's or flex-coils with no TXV installed.

LIMITATIONS

These units must be wired and installed in accordance with all national and local safety codes. Voltage limits are as follows:

Normal Operating voltage Range ¹	187-253
---	---------

1. Utilization range "A" in accordance with ARI Std. 110.

Air flow must be within the minimum and maximum limits approved for electric heat, evaporator coils and outdoor units:

Entering Air Temperature Limits			
Wet Bulb Temp. °F		Dry Bulb Temp. °F	
Min.	Max.	Min.	Max.
57	72	65	95

EXTENDED AIRFLOW DATA¹ FOR 230 VOLT - HEAT PUMP MODELS

Models	Blower Motor Speed	230 Volt									
		CFM @ External Static Pressure - IWC									
		0.10	0.20	0.30	0.40	0.50	0.60	0.70	0.80	0.90	1.00
F4FP024H06T**	High	950	910	865	835	775	730	662	590	502	400
	Med	845	815	785	745	705	654	594	524	439	344
	Low	650	630	605	575	540	508	450	383	285	158
F4FP030H06T**	High	1,270	1,210	1,150	1,085	1,015	946	862	769	645	502
	Med	1,050	1,040	995	930	855	804	714	624	494	364
	Low	855	820	780	735	680	624	550	447	333	190
F4FP036H06T**	High	–	1,310	1,250	1,175	1,120	1,053	983	894	779	645
	Med	1,200	1,150	1,100	1,040	985	933	879	795	711	587
	Low	1,060	1,015	970	925	860	809	740	661	572	453
F4FP040H06T**	High	1,270	1,210	1,150	1,085	1,015	946	802	769	645	502
	Med	1,050	1,040	995	930	855	804	714	624	494	364
	Low	855	820	780	735	680	624	550	447	333	190
F4FP042H06T**	High	–	1,575	1,500	1,420	1,350	1,273	1,192	1,102	996	871
	Med	1,460	1,395	1,330	1,260	1,190	1,125	1,052	960	842	695
	Low	1,250	1,200	1,155	1,100	1,050	1,001	931	851	751	631
F4FP045H06T**	High	1,575	1,535	1,475	1,390	1,310	1,245	1,147	1,030	897	735
	Med High	1,375	1,315	1,255	1,185	1,110	1,040	944	848	732	606
	Med Low	1,210	1,160	1,110	1,050	980	921	844	737	640	533
	Low	1,035	990	940	890	825	770	698	616	524	432
F5FP048H06T**	High	2223	2158	2090	2029	1929	1861	1788	1679	1594	1501
	Med High	1948	1904	1801	1815	1777	1741	1681	1618	1539	1453
	Med	1741	1690	1649	1606	1564	1516	1476	1436	1387	1353
	Med Low	1499	1454	1415	1370	1328	1269	1228	1191	1132	1093
	Low	1286	1233	1177	1142	1092	1039	987	960	888	842
F5FP060H06T**	High	2195	2145	2070	2008	1920	1852	1754	1663	1570	1462
	Med High	1938	1899	1873	1824	1791	1724	1679	1603	1521	1420
	Med	1726	1681	1641	1607	1560	1517	1485	1433	1402	1349
	Med Low	1525	1483	1441	1383	1356	1291	1253	1208	1169	1123
	Low	1306	1254	1204	1160	1114	1061	1008	980	914	876
F4FV060H06T**	REFER TO INFORMATION ON PAGE 6.										

NOTE: Air flow data shown above 0.50" W.C. external static pressure is for REFERENCE ONLY. Maximum allowable external static when electric heat is used is limited to 0.50" W.C. Maximum allowable external static pressure may also be limited by minimum CFM requirements for proper Heat Pump operation.

1. Includes Return Air Filter and Largest Electric Heater.

All F*FP series air handler units are UL Listed up to 0.50" w.c. external static pressure, including air filter, wet coil, and largest KW size heater.

EXTENDED AIR FLOW DATA¹ FOR 208 VOLT - HEAT PUMP MODELS

Models	Blower Motor Speed	208 Volt									
		CFM @ External Static Pressure - IWC									
		0.10	0.20	0.30	0.40	0.50	0.60	0.70	0.80	0.90	1.00
F4FP024H06T**	High	855	819	779	752	698	657	596	531	452	360
	Med.	760	733	706	670	634	589	535	472	395	310
	Low	585	567	545	518	486	457	405	344	257	142
F4FP030H06T**	High	1143	1089	1035	977	914	851	776	692	581	451
	Med.	941	936	895	837	770	724	643	562	445	328
	Low	770	738	702	662	612	561	495	402	300	171
F4FP036H06T**	High	1235	1179	1125	1058	1008	947	885	804	701	580
	Med.	1080	1035	990	936	887	840	791	716	640	528
	Low	954	914	873	833	774	728	666	595	515	408
F4FP040H06T**	High	1143	1089	1035	977	914	851	776	692	581	451
	Med.	941	936	895	837	770	724	643	562	445	328
	Low	770	738	702	662	612	561	495	402	300	171
F4FP042H06T**	High	1400	1418	1350	1278	1215	1145	1073	991	897	784
	Med.	1314	1266	1197	1135	1071	1012	947	864	758	625
	Low	1125	1080	1040	990	945	901	838	766	676	568
F4FP045H06T**	High	1418	1382	1328	1251	1179	1120	1032	927	807	661
	Med-high	1238	1184	1130	1067	999	936	850	763	659	545
	Med-low	1089	1044	999	945	882	829	760	663	576	480
	Low	932	891	846	801	743	693	628	554	472	389
F5FP048H06T**	High	2209	2140	2093	2000	1939	1864	1746	1724	1655	1587
	Med High	1945	1906	1871	1819	1784	1741	1667	1640	1595	1550
	Med	1739	1690	1640	1602	1559	1516	1470	1431	1387	1343
	Med Low	1506	1464	1415	1369	1325	1283	1238	1193	1139	1100
	Low	1301	1248	1197	1151	1095	1054	1005	958	909	860
F5FP060H06T**	High	2134	2124	2052	1979	1861	1756	1639	1597	1512	1427
	Med High	1916	1875	1838	1777	1744	1671	1594	1584	1537	1490
	Med	1716	1671	1613	1569	1523	1475	1429	1384	1337	1290
	Med Low	1494	1435	1390	1341	1284	1241	1194	1139	1087	1036
	Low	1276	1223	1168	1115	1068	1009	965	902	847	792
F4FV060H06T**	REFER TO INFORMATION ON PAGE 6.										

NOTE: Air flow data shown above 0.50" W.C. external static pressure is for REFERENCE ONLY. Maximum allowable external static when electric heat is used is limited to 0.50" W.C. Maximum allowable external static pressure may also be limited by minimum CFM requirements for proper Heat Pump operation.

1. Includes Return Air Filter and Largest Electric Heater.

All F*FP series air handler units are UL Listed up to 0.50" w.c. external static pressure, including air filter, wet coil, and largest KW size heater.

APPLICATION FACTORS-RELATED CFM VS. ACTUAL CFM

% Of Rated Airflow	80%	90%	RATED CFM	110%	120%
Capacity Factor	0.96	0.98	1.00	1.02	1.03

EXTENDED AIR FLOW DATA - F4FV VARIABLE SPEED MODELS

CFM/TAP SELECTION - F4FV

High Speed	Cooling and	Heat Pump CFM
Model	Jumper	Setting
F4FV060H06T	"COOL" TAP	"ADJ TAP"
2100	"A"	"B"
1980	"B"	"B"
1860	"A"	"A"
1750	"B"	"A"
1675	"A"	"C"
1605	"C"	"B"
1575	"B"	"C"
1510	"D"	"B"
1420	"C"	"A"
1335	"D"	"A"
1280	"C"	"C"
1200	"D"	"C"

NOTES:

- Both the "COOL" and the "ADJ" tap must be set for the cooling CFM.
- Fan only CFM = 63% of high speed cooling.
- Low speed cooling used only with two stage outdoor units. (Speed is preset to 65% of high speed).
- Dehumidification speed is 85% of cooling speed.
- When operating in both heat pump and electric heat modes, the CFM will be whichever is greater.
- CFM indicator light flashes once for every 100 CFM (i.e., 12 Flashes is 1200 CFM).
- All CFM's are shown at 0.5" wc external static pressure. This unit has a variable speed motor that automatically adjusts to provide constant CFM from 0.1" to 0.6" wc static pressure, the CFM is reduced by 2% per 0.1" increase in static pressure. Operation on duct systems with greater the 1.0" wc external static pressure is not recommended.

ELECTRIC HEAT CFM

Model	CFM	Tap Selections "HEAT"
F4FV060H06T**	1860	"A"
	1750	"B"
	1420	"C"
	1335	"D"

DELAY PROFILE

"DELAY" Tap	Comfort Setting
A	Normal
B	Humid
C	Dry
D	Temperate

Normal

The normal setting provides a 30-second ramp-up from zero airflow to full capacity and a 30-second ramp-down from full capacity back to zero airflow. Whenever there is a change in airflow mode, such as a call for cooling or a change from low heat to high heat, the motor will take 30 seconds to ramp from one speed to the other.

Humid

The humid setting is best-suited for installations where the humidity is frequently very high during cooling season, such as in the southern part of the country. On a call for cooling, the blower will ramp up to 50% of full capacity and will stay there for two minutes, then will ramp up to 82% of full capacity and will stay there for five minutes, and then will ramp up to full capacity, where it will stay until the wall thermostat is satisfied. In every case, it will take the motor 30 seconds to ramp from one speed to another.

Dry

The dry setting is best suited to parts of the country where excessive humidity is not generally a problem, where the summer months are usually dry. On a call for cooling the motor will ramp up to full capacity and will stay there until the thermostat is satisfied. At the end of the cooling cycle, the blower will ramp down to 50% of full capacity where it will stay for 60 seconds. Then it will ramp down to zero. In every case, it will take the motor 30 seconds to ramp from one speed to another.

Temperate

The temperate setting is best suited for most of the country, where neither excessive humidity nor extremely dry conditions are the norm. On a call for cooling, the motor will ramp up to 63% of full capacity and will stay there for 90 seconds, then will ramp up to full capacity. At the end of the cooling cycle, the motor will ramp down to 63% of full capacity and will stay there for 30 seconds, then will ramp down to zero. In every case, it will take the motor 30 seconds to ramp from one speed to another.

Physical and Electrical Data

MODEL		F4FP024H06T**	F4FP030H06T**	F4FP036H06T**	F4FP040H06T**	F4FP042H06T**	F4FP045H06T**
Blower - Diameter Width		10x6	10x8	10x8	10x8	10x8	10x10
Motor	HP	1/4	1/3	1/2	1/3	3/4	1/3
	Nominal RPM	1075	1075	1075	1075	1130	925
Voltage		208/230					
AMPS	Full Load	1.6/1.4	2.5/2.2	3.3/2.9	2.5/2.2	4.4/3.8	3.0/2.7
	Locked Rotor	3.3/2.9	6.2/5.5	7.4/6.5	6.2/5.5	11.9/10.3	4.8/4.1
Filter ¹	Type	Disposable/Permanent					
	Size	16x20x1	16x20x1	20x20x1	20x20x1	20x20x1	22x20x1
	Permanent Type Kit	1PF0601BK	1PF0601BK	1PF0602BK	1PF0601BK	1PF0602BK	1PF0603BK
Shipping/Operating Weight (lbs.)		98/93	105/100	115/109	121/115	121/115	150/144
MODEL		F5FP048H06T**	F5FP060H06T**	F4FV060H06T**			
Blower - Diameter x Width		11x10	11x10	11x10			
Motor	HP	1.0	1.0	1.0			
	Nominal RPM	1050	1050	1200			
Voltage		230					
Amps	Full Load	7.6	7.6	7.8/7.0			
	Locked Rotor	-	-	-			
Filter ¹	Type	Disposable/Permanent					
	Size	22x20x1	22x20x1	22x20x1			
	Permanent Type Kit	1PF0603BK	1PF0603BK	1PF0603BK			
Shipping/Operating Weight (lbs.)		153/147	160/154	160/154			

1. Field Supplied.

ELECTRICAL DATA - Cooling Only

Models	Total Motor Amps		Minimum Circuit ampacity		Max. O.C.P. ¹ Amps/Type	Minimum Wire Size A.W.G.
	208V	240V	208V	240V		
F4FP024H06T**	1.6	1.5	2.0	1.8	15	14
F4FP030H06T**	2.5	2.3	3.2	2.8	15	14
F4FP036H06T**	3.3	3.0	4.2	3.7	15	14
F4FP040H06T**	2.5	2.3	3.2	2.8	15	14
F4FP042H06T**	4.4	4.0	5.5	4.8	15	14
F4FP045H06T**	3.1	2.6	3.9	3.4	15	14
F5FP048H06T**	7.6	7.6	9.5	9.5	15	14
F5FP060H06T**	7.6	7.6	9.5	9.5	15	14
VARIABLE SPEED MODEL						
F4FV060H06T**	7.8	7.0	9.7	8.8	15	14

1. O.C.P. = Over Current Protection device, must be HACR type Circuit Breaker or Time Delay Fuse.

ELECTRICAL DATA - 1Ø - 208/230 - 1-60

Models	Heater ¹ Model	MAX. STATIC & MIN. CFM		Total Heat ²				KW Staging ³					
				KW		MBH		W1 Only		W2 Only		W1 + W2	
		Static	Tap	208V	240V	208V	240V	208V	240V	208V	240V	208V	240V
F4FP024H06T**	2HK*6500506B	0.5	Low	3.8	5.0	13.0	17.1	3.8	5.0	3.8	5.0	3.8	5.0
	2HK*6500806B		Low	5.6	7.5	19.1	25.6	3.8	5.0	5.6	7.5	5.6	7.5
	2HK*6501006B		Low	7.5	10.0	25.6	34.1	3.8	5.0	7.5	10.0	7.5	10.0
F4FP030H06T**	2HK*6500506B	0.5	Low	3.8	5.0	13.0	17.1	3.8	5.0	3.8	5.0	3.8	5.0
	2HK*6500806B		Low	5.6	7.5	19.1	25.6	3.8	5.0	5.6	7.5	5.6	7.5
	2HK*6501006B		Low	7.5	10.0	25.6	34.1	3.8	5.0	7.5	10.0	7.5	10.0
	2HK16501506B		High	11.3	15.0	38.6	51.2	3.8	5.0	7.5	10.0	11.3	15.0
F4FP036H06T**	2HK*6500506B	0.5	Low	3.8	5.0	13.0	17.1	3.8	5.0	3.8	5.0	3.8	5.0
	2HK*6500806B		Low	5.6	7.5	19.1	25.6	3.8	5.0	5.6	7.5	5.6	7.5
	2HK*6501006B		Low	7.5	10.0	25.6	34.1	3.8	5.0	7.5	10.0	7.5	10.0
	2HK16501506B		Med	11.3	15.0	38.6	51.2	3.8	5.0	7.5	10.0	11.3	15.0
	2HK16501906B ⁴		High	13.2	17.6	45.1	60.1	2.8	3.8	10.4	13.8	13.2	17.6
F4FP040H06T**	2HK*6500506B	0.5	Low	3.8	5.0	13.0	17.1	3.8	5.0	3.8	5.0	3.8	5.0
	2HK*6500806B		Low	5.6	7.5	19.1	25.6	3.8	5.0	5.6	7.5	5.6	7.5
	2HK*6501006B		Low	7.5	10.0	25.6	34.1	3.8	5.0	7.5	10.0	7.5	10.0
	2HK16501506B		High	11.3	15.0	38.6	51.2	3.8	5.0	7.5	10.0	11.3	15.0
F4FP042H06T**	2HK*6500506B	0.5	Low	3.8	5.0	13.0	17.1	3.8	5.0	3.8	5.0	3.8	5.0
	2HK*6500806B		Low	5.6	7.5	19.1	25.6	3.8	5.0	5.6	7.5	5.6	7.5
	2HK*6501006B		Low	7.5	10.0	25.6	34.1	3.8	5.0	7.5	10.0	7.5	10.0
	2HK16501506B		Low	11.3	15.0	38.6	51.2	3.8	5.0	7.5	10.0	11.3	15.0
F4FP045H06T**	2HK*6500506B	0.5	Low	3.8	5.0	13.0	17.1	3.8	5.0	3.8	5.0	3.8	5.0
	2HK*6500806B		Low	5.6	7.5	19.1	25.6	3.8	5.0	5.6	7.5	5.6	7.5
	2HK*6501006B		Med	7.5	10.0	25.6	34.1	3.8	5.0	7.5	10.0	7.5	10.0
	2HK16501506B		High	11.3	15.0	38.6	51.2	3.8	5.0	7.5	10.0	11.3	15.0
F5FP048H06T**	2HK16500506B	0.5	Med-Low	3.8	5.0	13.0	17.1	3.8	5.0	3.8	5.0	3.8	5.0
	2HK16500806B		Med-Low	5.6	7.5	19.1	25.6	3.8	5.0	5.6	7.5	5.6	7.5
	2HK*6501006B		Med-Low	7.5	10.0	25.6	34.1	3.8	5.0	7.5	10.0	7.5	10.0
	2HK16501506B		Med-Low	11.3	15.0	38.6	51.2	3.8	5.0	7.5	10.0	11.3	15.0
	2HK16502006B		Med-Low	15.0	20.0	51.2	68.3	3.8	5.0	11.3	15.0	15.0	20.0
	2HK16502506B		Med-Low	18.8	25.0	64.2	85.3	3.8	5.0	11.3	15.0	18.8	25.0
F5FP060H06T**	2HK*6501006B	0.5	Med	3.8	5.0	13.0	17.1	3.8	5.0	3.8	5.0	3.8	5.0
	2HK16500806B		Med	5.6	7.5	19.1	25.6	3.8	5.0	5.6	7.5	5.6	7.5
	2HK16501006B		Med	7.5	10.0	25.6	34.1	3.8	5.0	7.5	10.0	7.5	10.0
	2HK16501506B		Med	11.3	15.0	38.6	51.2	3.8	5.0	7.5	10.0	11.3	15.0
	2HK16502006B		Med	15.0	20.0	51.2	68.3	3.8	5.0	7.5	10.0	15.0	20.0
	2HK16502506B		Med	18.8	25.0	64.2	85.3	3.8	5.0	11.3	15.0	18.8	25.0
F4FV060H06T**	2HK*6500806B	0.5	Heat/D	5.6	7.5	19.1	25.6	3.8	5.0	5.6	7.5	5.6	7.5
	2HK*6501006B		Heat/D	7.5	10.0	25.6	34.1	3.8	5.0	7.5	10.0	7.5	10.0
	2HK16501506B		Heat/D	11.3	15.0	38.6	51.2	3.8	5.0	7.5	10.0	11.3	15.0
	2HK16502006B		Heat/D	15.0	20.0	51.2	68.3	3.8	5.0	7.5	10.0	15.0	20.0
	2HK16502506B		Heat/D	18.8	25.0	64.2	85.3	3.8	5.0	11.3	15.0	18.8	25.0

NOTE: All models available with factory installed horizontal drain pan.

- 0 or as follows: 0 = No Breaker, 1 = Breaker.
- See Conversion Table below:
- If first stage heat or 66 is connected to W1, otherwise refer to this table.
- 2HK16501906B only applies to F4FP036 Model.

KW & MBH CONVERSIONS - FOR TOTAL POWER INPUT REQUIREMENT

FOR	230V	OPERATION MULTIPLY	240V	TABULATED KW & MBH BY	.918
-----	------	--------------------	------	-----------------------	------

ELECTRICAL DATA - 1Ø (SINGLE SOURCE POWER SUPPLY) - COPPER WIRE

Models	Heater Model ¹	Heater Amps 240V	Field Wiring					
			Min. Circuit Ampacity		Max. O.C.P. ² Amps/Type		75°C Wire Size - AWG	
			208V	240V	208V	240V	208V	240V
F4FP024H06T**	2HK*6500506B	20.8	24.7	27.7	25	30	10	10
	2HK*6500806B	31.3	35.5	40.7	40	45	8	8
	2HK*6501006B	41.7	46.9	53.7	50	60	8	6
F4FP030H06T**	2HK*6500506B	20.8	25.8	28.7	30	30	10	10
	2HK*6500806B	31.3	36.7	41.7	40	45	8	8
	2HK*6501006B	41.7	48.1	54.7	50	60	8	6
	2HK16501506B	62.5	70.9	80.8	80	90	4	3
F4FP036H06T**	2HK*6500506B	20.8	26.8	29.5	30	30	10	10
	2HK*6500806B	31.3	37.7	42.6	40	45	8	8
	2HK*6501006B	41.7	49.1	55.6	50	60	8	6
	2HK16501506B	62.5	71.9	81.6	80	90	4	3
	2HK16501906B ³	73.3	83.3	95.2	90	100	3	3
F4FP040H06T**	2HK*6500506B	20.8	25.8	28.7	30	30	10	10
	2HK*6500806B	31.3	36.7	41.7	40	45	8	8
	2HK*6501006B	41.7	48.1	54.7	50	60	8	6
	2HK16501506B	62.5	70.9	80.8	80	90	4	3
F4FP042H06T**	2HK*6500506B	20.8	28.1	30.5	30	35	10	8
	2HK*6500806B	31.3	38.9	43.6	40	45	8	8
	2HK*6501006B	41.7	50.3	56.6	60	60	6	6
	2HK16501506B	62.5	73.2	82.6	80	90	4	3
F4FP045H06T**	2HK*6500506B	20.8	26.6	29.3	30	30	10	10
	2HK*6500806B	31.3	37.4	42.3	40	45	8	8
	2HK*6501006B	41.7	48.8	55.3	50	60	8	6
	2HK16501506B	62.5	71.7	81.4	80	90	4	3
F5FP048H06T**	2HK16500506B	20.8	32.8	35.6	35	40	8	8
	2HK*6500806B	31.3	43.0	48.4	45	50	8	8
	2HK*6501006B	41.7	55.3	61.5	60	70	6	4
	2HK16501506B	62.5	77.3	87.8	80	90	4	3
	2HK16502006B	83.3	101.0	113.8	110	125	2	1
	2HK16502506B	104.2	124.3	139.9	125	150	1	1/0
F5FP060H06T**	2HK*6500506B	20.8	32.8	35.6	35	40	8	8
	2HK*6500806B	31.3	42.9	48.3	45	50	8	8
	2HK*6501006B	41.7	55.3	61.6	60	70	6	4
	2HK16501506B	62.5	78.5	87.8	80	90	4	3
	2HK16502006B	83.3	101.0	113.8	110	125	2	1
	2HK16502506B	104.2	122.2	139.5	125	150	1	1/0
F4FV060H06T**	2HK*6500806B	31.3	43.8	47.8	45	50	8	8
	2HK*6501006B	41.7	55.2	60.8	60	70	6	4
	2HK16501506B	62.5	78.0	86.9	80	90	4	3
	2HK16502006B	83.3	100.3	112.9	110	125	2	1
	2HK16502506B	104.2	123.1	139.0	125	150	1	1/0

- 0 or 1 as follows: 0 = No Breaker, 1 = Breaker
- OCP = Over Current Protection device, must be HACR type Circuit Breaker or Time Delay fuse.
- 2HK16501906B only applies to F4FP036 Model.

ELECTRICAL DATA - 1 Ø (MULTI-SOURCE POWER SUPPLY) - COPPER WIRE

Models	Heater Model	Min. Circuit Ampacity			Max. O.C.P. ¹ Amps/Type			75°C Wire Size - AWG		
		Circuit			Circuit			Circuit		
		1st	2nd	3rd	1st	2nd	3rd	1st	2nd	3rd
		208/240V	208/240V	208/240V	208/240V	208/240V	208/240V	208/240V	208/240V	208/240V
F4FP030H06T**	2HK16501506B	25.8/28.7	45.1/52.1	–	30/30	50/60	–	10/10	8/6	–
F4FP036H06T**	2HK16501506B	26.8/29.5	45.1/52.1	–	30/30	50/60	–	10/10	8/6	–
	2HK16501906B ²	38.3/42.6	45.7/52.6	–	40/45	50/60	–	8/8	8/6	–
F4FP040H06T**	2HK16501506B	25.8/28.7	45.1/52.1	–	30/30	50/60	–	10/10	8/6	–
F4FP042H06T**	2HK16501506B	28.1/30.5	45.1/52.1	–	30/35	50/60	–	10/8	8/6	–
F4FP045H06T**	2HK16501506B	26.6/29.3	45.1/52.1	–	30/30	50/60	–	10/10	8/6	–
F5FP048H06T**	2HK16501506B	32.8/35.6	45.1/52.1	–	35/40	50/60	–	8/8	8/6	–
	2HK16502006B	55.3/61.6	45.1/52.1	–	60/70	50/60	–	6/4	8/6	–
	2HK16502506B	32.8/35.6	45.1/52.1	45.1/52.1	35/40	50/60	50/60	8/8	8/6	8/6
F5FP060H06T**	2HK16501506B	32.8/35.6	45.1/52.1	–	35/40	50/60	–	8/8	8/6	–
	2HK16502006B	55.3/61.6	45.1/52.1	–	60/70	50/60	–	6/4	8/6	–
	2HK16502506B	33.8/35.6	45.1/52.1	45.1/52.1	35/40	50/60	50/60	8/8	8/6	8/6
F4FV060H06T**	2HK16501506B	33.0/34.8	45.1/52.1	–	35/35	50/60	–	8/8	8/6	–
	2HK16502006B	55.2/60.8	45.1/52.1	–	60/70	50/60	–	6/4	8/6	–
	2HK16502506B	33.0/34.8	45.1/52.1	45.1/52.1	35/35	50/60	50/60	8/8	8/6	8/6

1. OCP = Over Current Protection device, must be HACR type Circuit Breaker or Time Delay fuse.
2. 2HK16501906B only applies to F4FP036 Model.

ELECTRICAL DATA - 3 Ø - 208/230-3-60

Models	Heater Model	MAX. STATIC & MIN. CFM		Total Heat ¹				KW Staging ²					
				KW		MBH		W1 Only		W2 Only		W1 + W2	
		Static	Tap	208V	240V	208V	240V	208V	240V	208V	240V	208V	240V
F4FP024H06T**	2HK06501025B	0.5	Low	7.5	10.0	25.6	34.1	3.8	5.0	7.5	5.0	7.5	10.0
F4FP030H06T**	2HK06501025B	0.5	Low	7.5	10.0	25.6	34.1	3.8	5.0	7.5	5.0	7.5	10.0
	2HK06501525B	0.5	High	11.3	15.0	38.6	51.2	3.8	5.0	7.5	10.0	11.3	15.0
F4FP036H06T**	2HK06501025B	0.5	Low	7.5	10.0	25.6	34.1	3.8	5.0	7.5	5.0	7.5	10.0
	2HK06501525B	0.5	High	11.3	15.0	38.6	51.2	3.8	5.0	7.5	10.0	11.3	15.0
F4FP040H06T**	2HK06501025B	0.5	Low	7.5	10.0	25.6	34.1	3.8	5.0	7.5	5.0	7.5	10.0
	2HK06501525B	0.5	High	11.3	15.0	38.6	51.2	3.8	5.0	7.5	10.0	11.3	15.0
F4FP042H06T**	2HK06501025B	0.5	Low	7.5	10.0	25.6	34.1	3.8	5.0	7.5	5.0	7.5	10.0
	2HK06501525B	0.5	Low	11.3	15.0	38.6	51.2	3.8	5.0	7.5	10.0	11.3	15.0
F4FP045H06T**	2HK06501025B	0.5	Med	7.5	10.0	25.6	34.1	3.8	5.0	7.5	5.0	7.5	10.0
	2HK06501525B	0.5	High	11.3	15.0	38.6	51.2	3.8	5.0	7.5	10.0	11.3	15.0
F5FP048H06T**	2HK06501025B	0.5	Med Low	7.5	10.0	25.6	34.1	3.8	5.0	7.5	5.0	7.5	10.0
	2HK06501525B	0.5	Med Low	11.3	15.0	38.6	51.2	3.8	5.0	7.5	10.0	11.3	15.0
F5FP060H06T**	2HK06501025B	0.5	Med	7.5	10.0	25.6	34.1	3.8	5.0	7.5	5.0	7.5	10.0
	2HK06501525B	0.5	Med	11.3	15.0	38.6	51.2	3.8	5.0	7.5	10.0	11.3	15.0
F4FV060H06T**	2HK06501025B	0.5	Heat/D	7.5	10.0	25.6	34.1	3.8	5.0	7.5	10.0	7.5	10.0
	2HK06501525B	0.5	Heat/D	11.3	15.0	38.8	51.2	3.8	5.0	7.5	10.0	11.3	15.0

1. See Conversion Table below.
2. If first stage heat is connected to W1/66, otherwise refer to Table below.

KW & MBH CONVERSIONS - FOR TOTAL POWER INPUT REQUIREMENT

FOR	230V	OPERATION MULTIPLY	240V	TABULATED KW & MBH BY	.918
-----	------	--------------------	------	-----------------------	------

ELECTRICAL DATA - 3Ø - (SINGLE SOURCE POWERSUPPLY) - COPPER WIRE

Models	Heater Models	Field Wiring					
		Min. Circuit Ampacity		Max. O.C.P. ¹ Amps		75°C Wire Size - AWG	
		208V	240V	208V	240V	208V	240V
F4FP024H06T**	2HK06501025B	41.2	46.5	45	50	8	8
F4FP030H06T**	2HK06501025B	42.2	47.4	45	50	8	8
	2HK06501525B	42.2	47.4	45	50	8	8
F4FP036H06T**	2HK06501025B	43.1	48.2	45	50	8	8
	2HK06501525B	43.1	48.2	45	50	8	8
F4FP040H06T**	2HK06501025B	42.2	47.4	45	50	8	8
	2HK06501525B	42.2	47.4	45	50	8	8
F4FP042H06T**	2HK06501025B	44.2	49.1	45	50	8	8
	2HK06501525B	44.2	49.1	45	50	8	8
F4FP045H06T**	2HK06501025B	42.8	47.9	45	50	8	8
	2HK06501525B	42.8	47.9	45	50	8	8
F5FP048H06T**	2HK06501025B	48.3	53.9	50	60	8	6
	2HK06501525B	48.3	53.9	50	60	8	6
F5FP060H06T**	2HK06501025B	48.3	53.9	50	60	8	6
	2HK06501525B	48.3	53.9	50	60	8	6
F4FV060H06T**	2HK06501025B	48.6	52.9	50	60	8	6
	2HK06501525B	48.6	52.9	50	60	8	6

1. O.C.P. = Over Current Protection device, must be HACR type Circuit Breaker or Time Delay fuse.

FIELD WIRING CONNECTION - COOLING ONLY

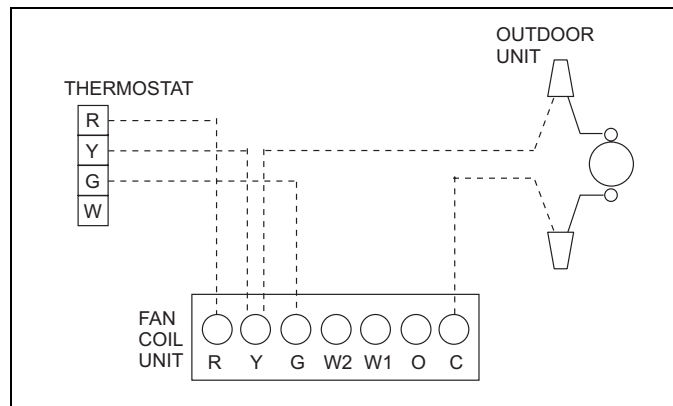

FIELD WIRING CONNECTION - WITH HEATER KIT

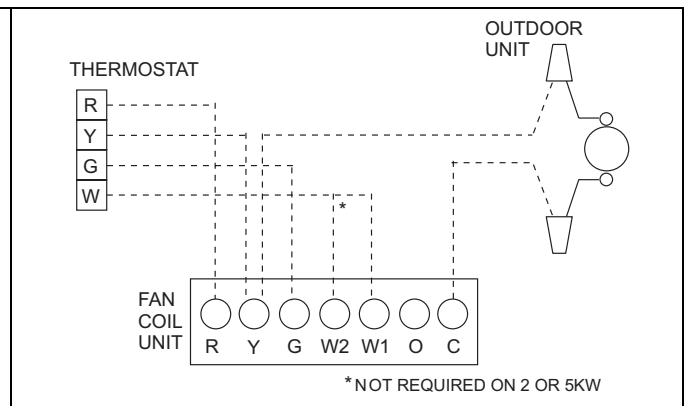

FIELD WIRING CONNECTIONS - COOLING MODELS WITH ELECTRIC HEAT WIRING

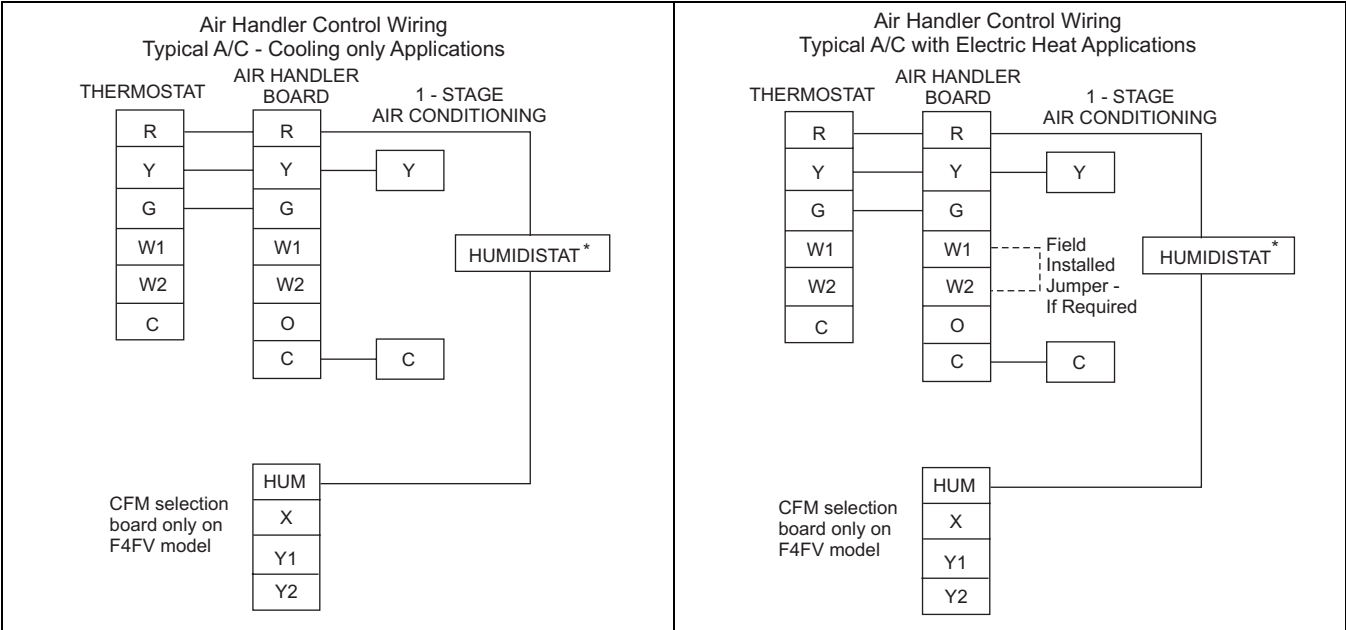

* Dehumidification control connection ("Humidistat" jumper on CFM selection board must be removed).

FIELD WIRING CONNECTIONS - SINGLE STAGE HEAT PUMP

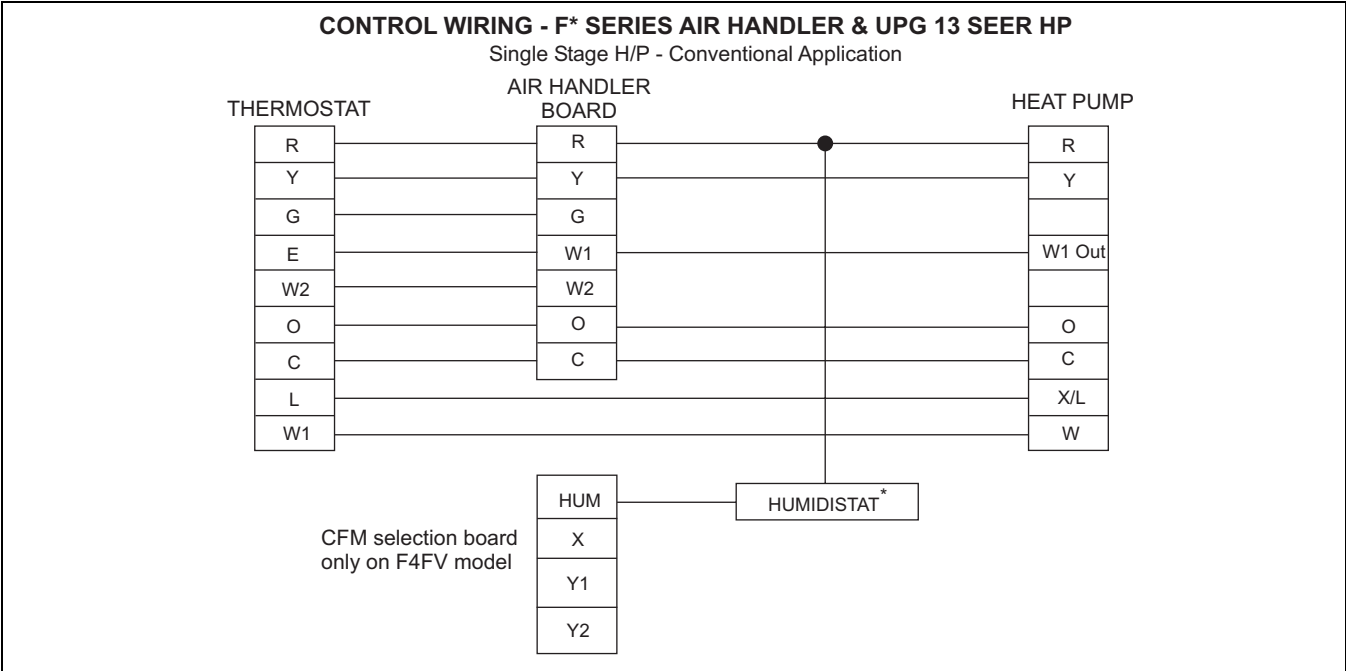

* Dehumidification control connection ("Humidistat" jumper on CFM selection board must be removed).

NOTES:

1. "Y" Terminal on Air Handler Control Board must be connected for full CFM and applications requiring 60 second Blower Off Delay for SEER enhancement.
2. Optional Dehumidification Humidistat contacts open on rise.
3. For F4FV model - Remove Humidistat Jumper on CFM Selection Board - if used.
4. For F4FV model - For Heat Pump Applications - Remove Heat Pump Jumper on CFM Selection Board.
5. To change quantity of heat during HP defrost cycle - Reverse connections at W1 and W2 on Air Handler Control Board.

TYPICAL INSTALLATION

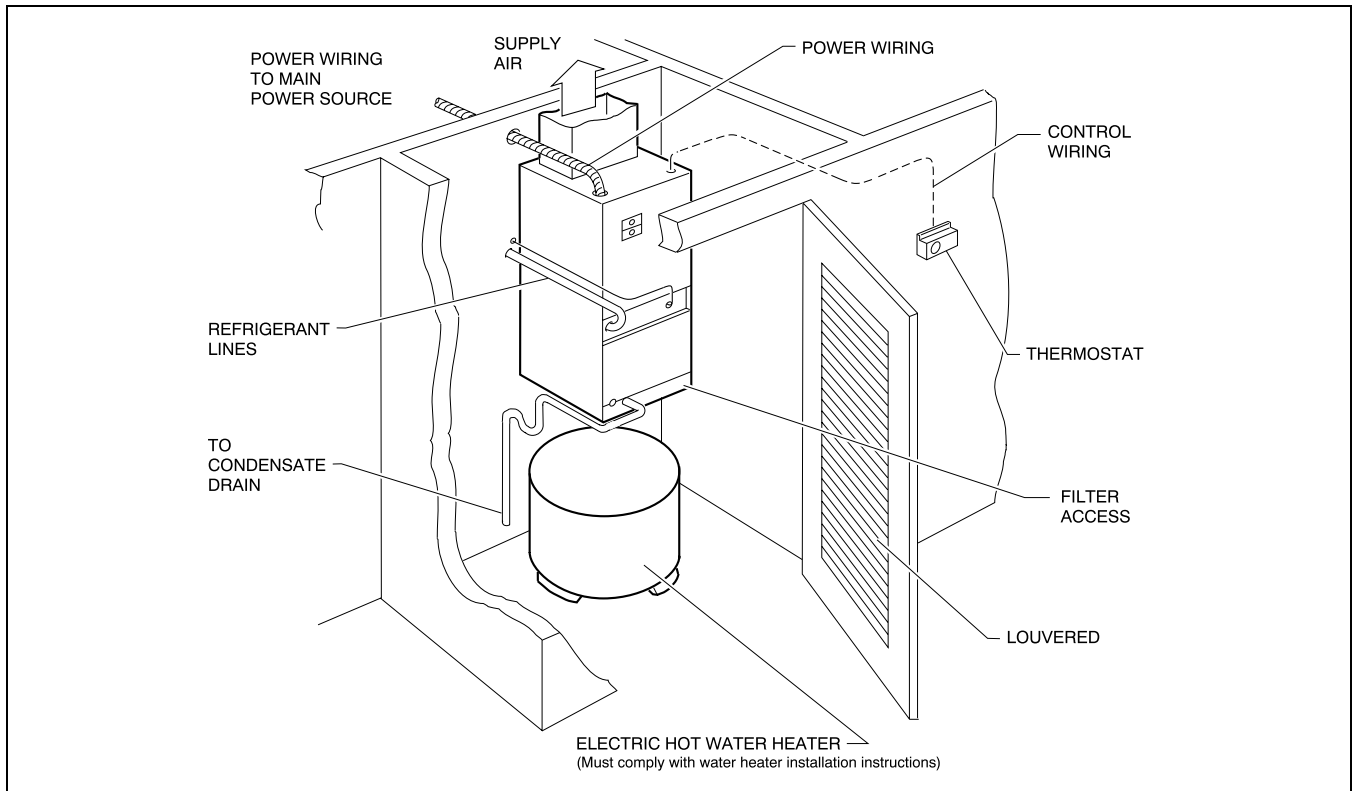

TYPICAL APPLICATIONS

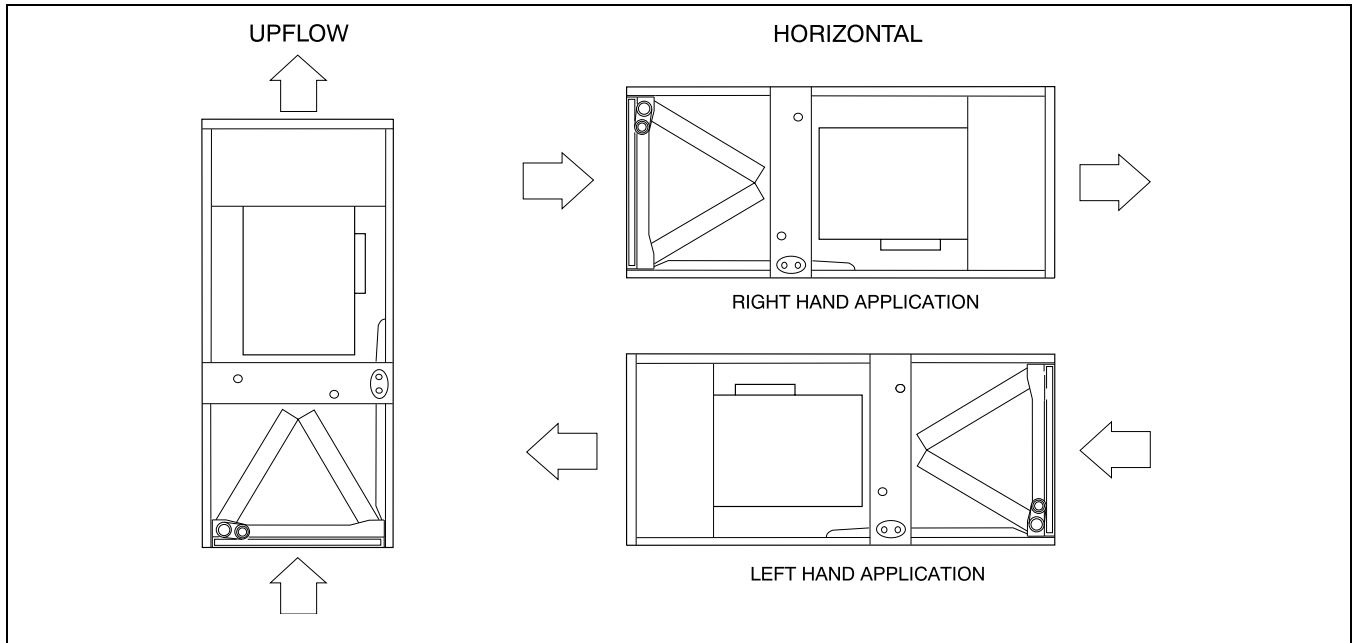

NOTES